

DETAIL A
EXPLODED VIEW

NOTE:
IF THE BUILDING HAS AN MR-24 ROOF, INSTALL TRIM CLIPS TO GABLE ANGLE BEFORE INSTALLING V-STRAPS. V-STRAPS MAY RUN OVER TRIM CLIP FASTENER.

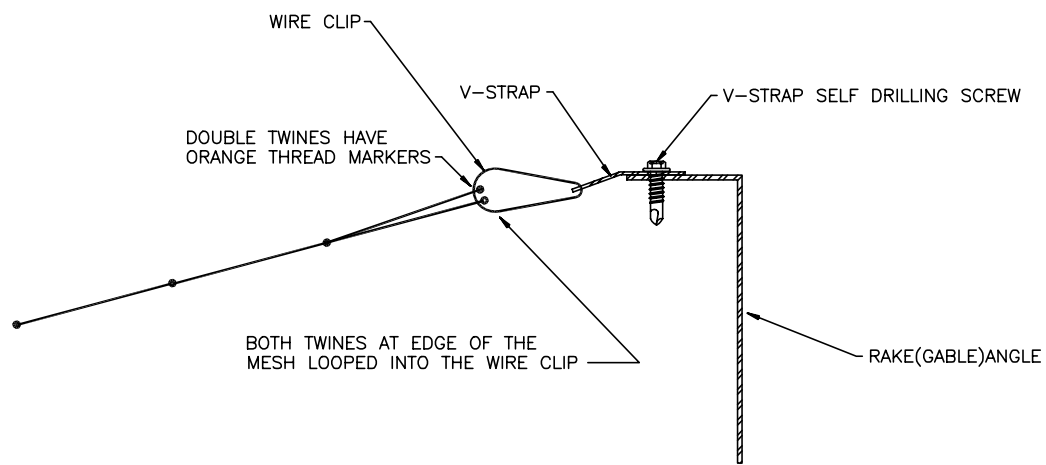

SECTION A-A
TYPICAL AT ENDWALL

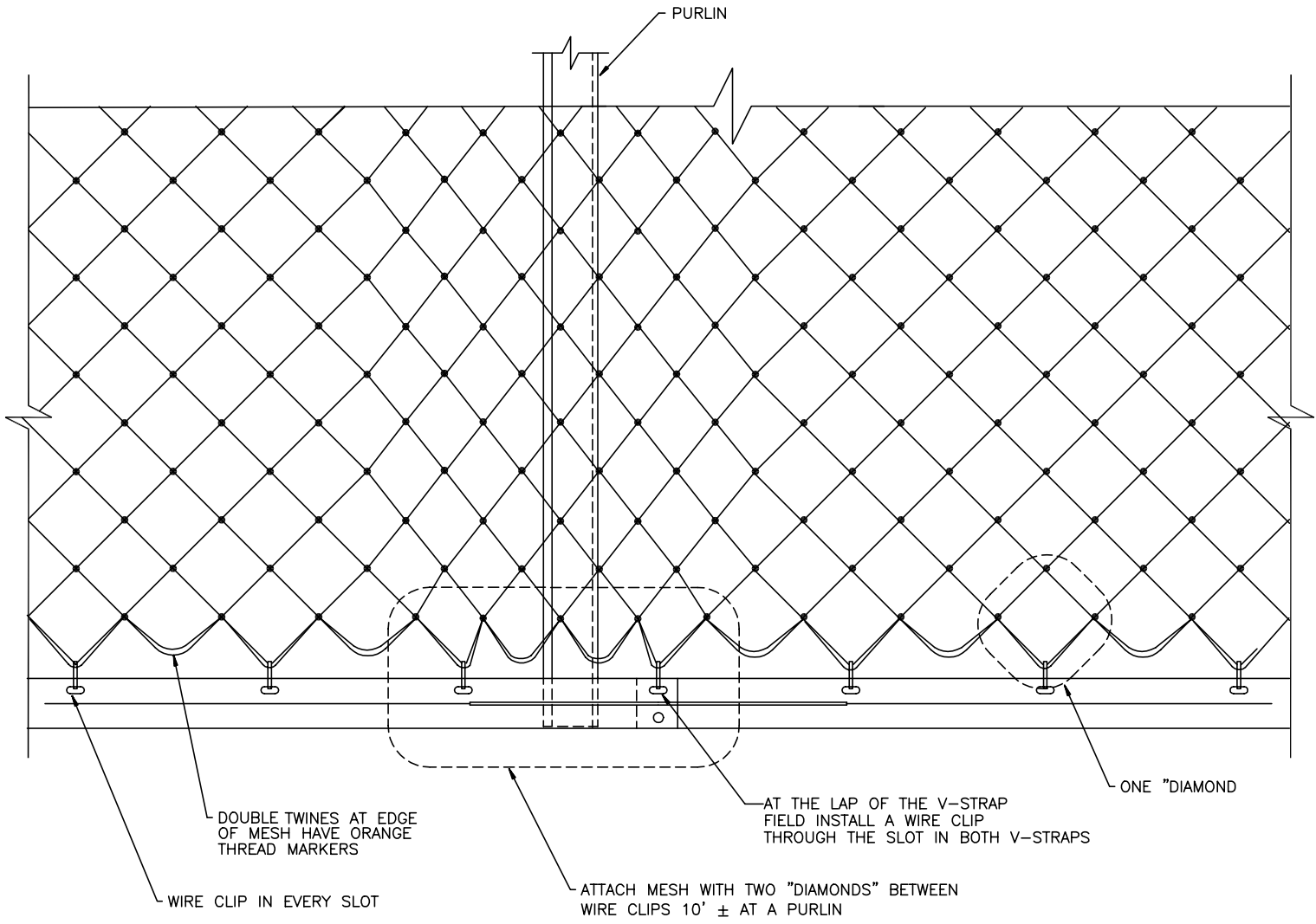



DETAIL B
TYPICAL PLAN VIEW AT ENDWALL

- STEPS:
1. VERIFY THAT THE TWINES AT THE EDGE OF THE MESH TO BE INSTALLED AT THE ENDWALL HAVE ORANGE THREAD MARKERS.
 2. LOOP THE MESH INTO THE WIRE CLIP AT EVERY OTHER "DIAMOND", EXCEPT AS SHOWN IN DETAIL B.
 3. MAKE SURE BOTH TWINES AT THE EDGE ARE LOOPED INTO THE WIRE CLIP.
 4. SEE DETAIL A FOR AN EXPLODED VIEW OF THE V-STRAP CONNECTION.

NOTE: USE THIS DRAWING ONLY IF INSULATION IS THICKER THAN 8"
(USE DRAWING 1081346 IF INSULATION IS 8" THICK OR LESS)

GROUP	DRAWING NUMBER	REV.
01-019-01	B 1081642	00

 AISC Certified for Design & Fabrication	THIS PRINT SUBJECT TO CHANGE WITHOUT NOTICE. FOR BUILDING ERECTION ALWAYS USE THE PRINTS RECEIVED WITH THE BUILDING SHIPMENT.	SKY-WEB II	ENDWALL DETAILS	ALL BUILDINGS
		 BUTLER MANUFACTURING COMPANY	DATE 07/12/06 GROUP 01-019-01	DRAWING NUMBER B 1081642 00